



Poco has been designed as a sleek slim-line desk-top unit

Poco mounted vertically takes up less than 50mm of desk space yet is capable of providing all the facilities required in the modern office. Poco is suitable for hot-desking, personal power as well as assisting in meeting the requirements of the Disability Discrimination Act (DDA) in the workplace by providing facilities, accessible to all, on the work surface.

Used in conjunction with underdesk units Poco provides a total solution for power and data connectivity at the workstation.

Based on an aluminium extrusion in lengths of up to 3 metres, Poco may be used to accommodate mains sockets, data and other connectors as a comprehensive desk top unit to the customers exact specification.



Poco may also be configured as a screen or tool rail hung unit with brackets available to suit most types of installation.

Standard colours - Silver anodised body - grey fascias and end caps.

Other colours available on request – may be subject to minimum order quantity .



Common Modular Components*

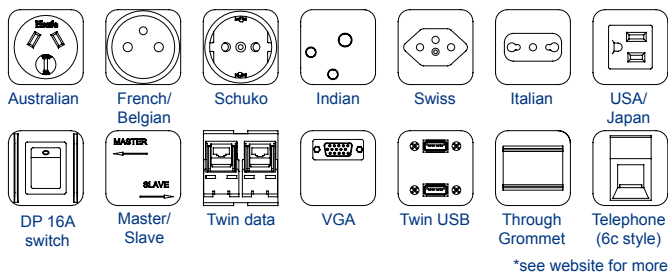

Standard Unit Lengths

poco 25/...

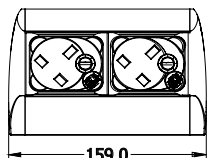

poco 50/...

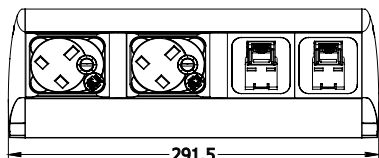

poco 75/...

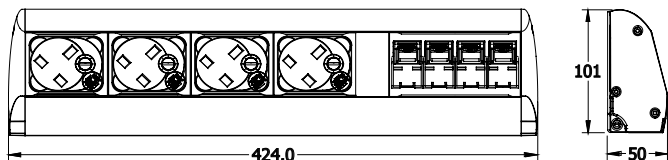

Standard Fixings

- CBV Vertical Clamp Bracket 13 - 40mm
- CBV-E Vertical Clamp Bracket (Extended) 25-55mm
- CBH Horizontal Clamp Bracket 20 - 35mm
- FTL Stick down fixing (Horizontal)
- TFB⁺ Top Fix Bracket (Horizontal)
- EB Eared Bracket (Vertical)*
- TRS Tool rail fixing (Vertical)*
- RF Rubber feet (Horizontal)

*Please call to confirm screen/toolrail compatibility

⁺TFB fixing is not 'soft' and cannot be changed on-site

Horizontal

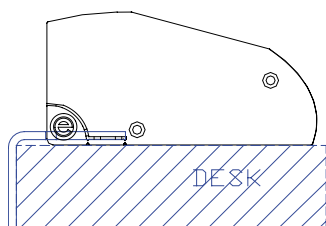

CBH - Horizontal Clamp Bracket

Desk Clamp available for desks with a thickness between 20 and 35mm

Custom brackets available on application

Screen Fixing

Screen/toolrail fixings can be provided to suit most applications - call our technical team for advice on which to use

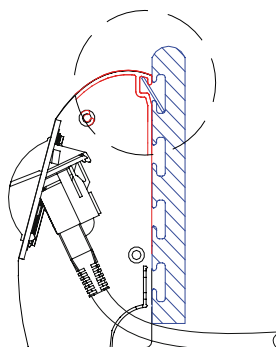

Angled data fascias allow data cabling to pass straight through POCO, ensuring the integrity of cables which have a minimum bend radii (CAT5e, CAT6, etc)

Vertical

CBV - Vertical Clamp Bracket

Vertical clamps are available for desk thicknesses between 13mm and 55mm

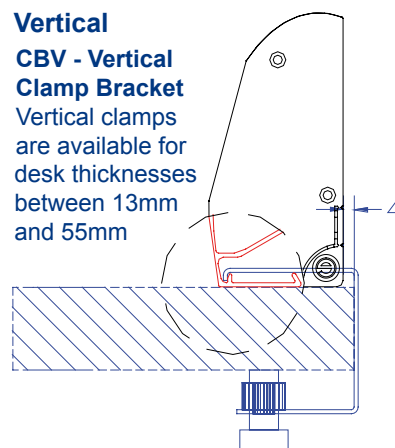

Features

Configuration:

Power only / Data only / Combined (Power & Data/AV)
 Internal segregation between Power and Data/AV in combined POCO units

Earthing:

Earthing is available from an earth slot in the rear of the unit to allow bonding to furniture (in accordance with BS6396). Earth leads are available on request.

Fusing: (to enable compliance to BS6396)

5 x 20mm anti-surge ceramic fuses, with colour-coded fuseclips to denote the rating (3.15A/5A)

Increased flexibility

- All POCOs are supplied with cables exiting the rear. However, side exit facility is available on all vertical units through a snap-out endcap. Side exit choice can be taken on site and does not require disassembly of POCO

Security:

ANTI-FLEX system: Unique full length locking system guarantees unit integrity regardless of length

Testing:

100% testing - continuity, polarity, insulation & earth

Soft Wiring (power)

Power hardwired to Wieland ST/GST connector allows starter cables to be changed to suit requirements, especially useful during moves and changes (CHURN)

Soft Wired Data

As well as soft-wired power, POCO can accommodate soft wired data. Using our inline couplers, data cables can be changed "on-site" to accommodate changes in length often associated with churn

Soft Fixing

POCO is designed to allow brackets to be changed on-site. Unless stated otherwise, POCO can simply be moved (using the same brkt) or attached to another feature on the desk simply by changing the bracket

